



DP-7022 stepper driver

User's manual

Content

1. Summary	1
1-1. Features	1
1-2. Application.....	1
1-3. Electrical features	1
2. Operation guide	2
2-1. Safety	2
2-2. Attention	2
2-3. Installation	2
3. Interface and function.....	3
3-1. Control signal interface.....	3
3-1-1. Function.....	3
3-1-2. Sequence chart of control signals	3
3-1-3. Input circuit	4
3-2. Power terminals	4
3-2-1. Function.....	4
3-2-2. Power supply requirements	5
3-2-3. Wiring	5
3-3. Mode setting	5
3-3-1. Current setting	5
3-3-2. Subdivision setting	6
3-4. Protection.....	6
4. Dimension and Installation	7
4-1. Dimension.....	7
4-2. Installation	7
4-3. Typical wiring.....	7
5. Problem and solution.....	9
6. Select the motor.....	10

1. Summary

DP-7022 subdivision stepper driver with 220VAC input voltage and 7.0A output current is used for all the three-phase hybrid stepper motor whose rated current is below 7.0A. Based on the digital control technology and sine wave current control technology, this series product makes the motor running smoothly with low noise, is suitable for high resolution equipments, such as laser marking machine, CNC machine etc.

1-1. Features

- Low noise on motor running.
- Power supply up to 220VAC
- Effective value of current up to 7.0A.
- Dynamic selectable subdivision up to 200.
- Can drive 3-phase stepper motor below 7.0A
- Photo isolator input signal.
- Easy-setting for current, any level selectable.
- Over-voltage and over-current protection.

1-2. Application

This series product can well meet the requirement of the small and medium automation devices and instruments, such as aerodynamic marking machine, labeling machine, cutting machine laser type machine, small carving tool, CNC machine etc., especially having a perfect performance on the devices with the requirement of low noise and vibration with high precision and speed.

1-3. Electrical features

Item	Min	Typical	Max
Power supply (VDC)	200	220	240
Output current virtual value (A)	0	—	5
Logical input current (mA)	4	7	16
Stepper pulse frequency (KHz)	0	—	200
Insulation resistor (MΩ)	500	—	—
Ambient temperature	0°C ~ 50°C		
Max working temperature	60°C		
Humidity	40% ~ 90% RH (no condensation)		
Vibration	5.9m/s ² Max		
Storage temperature	-20°C ~ 65°C		
Dimension	187mm × 121.4mm × 80mm		

2. Operation guide

Please read the following suggestion carefully before you install the driver.

2-1. Safety

- The driver is authorized to be installed and operated by the professional staff.
- Don't turn on the power before connecting to the motor.
- Make sure that the input signal meets the technical requirements.
- Don't make the setting or measure operations on the motor and driver during power on.
- Please do the wiring, installation and parameter setting after power is off for more than 3 minutes.
- Ensure the connection operation is absolutely correct and fixable before you turn on the power, including the power wire, motor cable and signal cable.
- Avoid electromagnetic interference.

2-2. Attention

- Please use shield cable for signal input, and leave each other for distance. The further the distance, the better the interference is avoided.
- Please connect the motor cover to the GND terminal.
- Don't operate the output terminal when power on, otherwise the driver will be damaged.

2-3. Installation

- Don't install the driver next to the heat source.
- Don't expose the driver to the dusty, corrosive gas, moist environment, and work in low vibration place.
- For perfect conducting, please ensure the fixation between earth wire of host computer, driver, motor and ground.

3. Interface and function

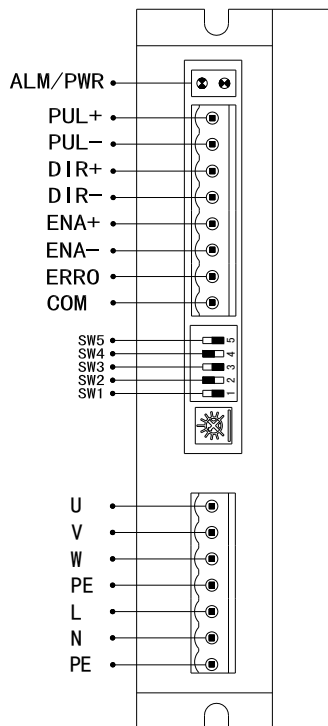

3-1. Control signal interface

3-1-1. Function

Signal	Function	Explanation
PUL+	Pulse signal	The motor moves one step at the rising edge of the signal. PUL—high voltage 4~5V, low voltage 0~0.5V.
PUL—		
DIR+	Direction signal	High/low voltage effective. Change the direction of the motor, the original direction of the motor is decided by the wiring, exchanging any phase can change the motor direction.
DIR—		
ENA+	Enable signal	To release the motor. When ENA+ connects to 5V and ENA—connects to low voltage, the driver will cut all phase current and be in free state, stepper pulse will not be responded. Please let the terminals vacant if out of use.
ENA—		
ERRO	Error signal	Output over-voltage, over-current signal.
COM		

3-1-2. Sequence chart of control signals

In order to ensure the system response reliability, the control signals should meet the following requirements:

- The signal effective high voltage is 24V; effective low voltage is less than 0.5V.
- ENA (enable signal) should change to high voltage 3 μ s before DIR (direction signal).
- Build the DIR (direction signal) 5 μ s before the PUL (pulse signal) falling edge.
- Pulse width should be more than 1.2 μ s.
- Pulse low voltage duration should be more than 1.2 μ s.

Sequence chart:

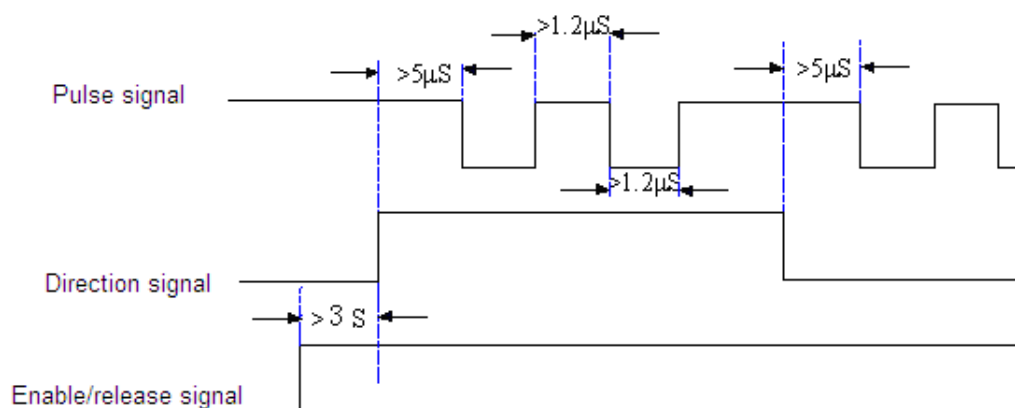

3-1-3. Input circuit

Common positive connection of input circuit:

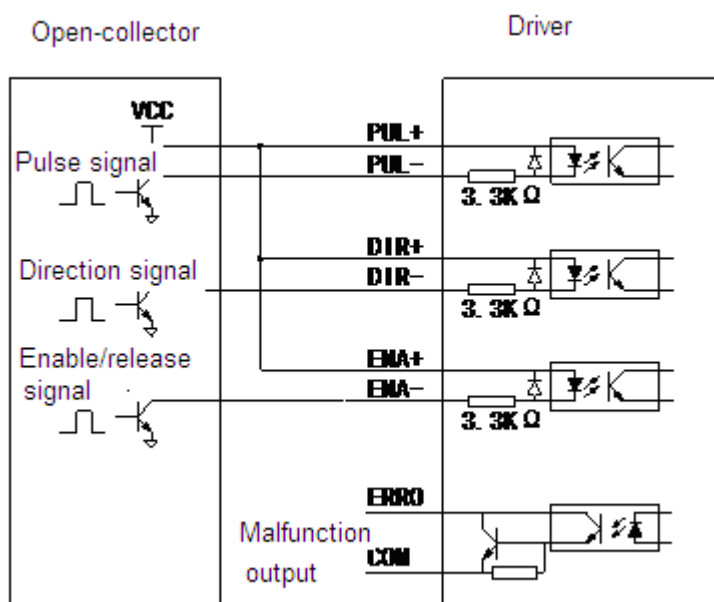

Input requirements:

- All the input signals go through the photo-electric isolation please provide at least 8mA control signal to ensure the conduction of built-in high-speed optical coupler.
- The photo-electric has installed limiting resistor, all the control signals connect to +24V.

3-2. Power terminals

3-2-1. Function

Interface	Function	Explanation
U	Motor phase U	Motor phase U input
V	Motor phase V	Motor phase V input
W	Motor phase W	Motor phase W input
PE	Ground	Power supply ground

L	Power supply	Power supply input, 200~240VAC
N		
PE	Ground	Power supply ground

3-2-2. Power supply requirements

- To keep the normal working of drive, please ensure the power supply in the range of 200~240VAC.

3-2-3. Wiring

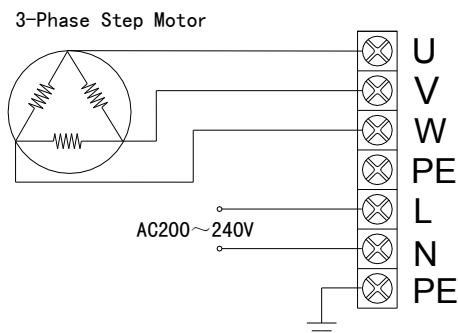

Notes:

The power supply voltage of driver determines the motor high speed performance (the larger the voltage, the higher the high-speed torque, can avoid loss of synchronism), set current determines the motor output torque (the bigger the current, the higher the output torque). However, when the power supply voltage is large, the vibration is large at low-speed; if set current is large, the driver and motor heat is very serious.

For actual applications, users can select suitable current to achieve well effect.

3-3. Mode setting

The driver has 5-bit DIP switch to set half/full current and subdivision resolution.

SW1: set half/full current (SW1=OFF: half current; SW1=ON: full current)

SW2~ SW5: set the subdivision resolution

3-3-1. Current setting

Single-turn potentiometer can set any current levels in the range of 0~7.0A:

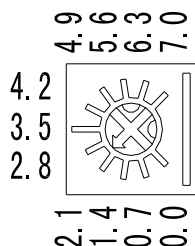

3-3-2. Subdivision setting

4-bit DIP switch SW2~SW5 can control the subdivision:

Subdivision time	step/circle (1.8°/full step)	SW2	SW3	SW4	SW5
1	200	OFF	OFF	OFF	OFF
2	400	OFF	OFF	OFF	ON
4	800	OFF	OFF	ON	OFF
8	1600	OFF	OFF	ON	ON
16	3200	OFF	ON	OFF	OFF
32	6400	OFF	ON	OFF	ON
64	12800	OFF	ON	ON	OFF
128	25600	OFF	ON	ON	ON
5	1000	ON	OFF	OFF	OFF
10	2000	ON	OFF	OFF	ON
20	4000	ON	OFF	ON	OFF
25	5000	ON	OFF	ON	ON
40	8000	ON	ON	OFF	OFF
50	10000	ON	ON	OFF	ON
100	20000	ON	ON	ON	OFF
200	40000	ON	ON	ON	ON

3-4. Protection

■ LED

Power LED: green means working fine

ALM LED: red means alarm, red LED always ON means over-current alarm, red LED flickering means over-voltage alarm.

■ Error output

ERRO, COM terminal will output error signal when the driver is under-voltage or over-voltage.

■ Over-current over-voltage protection

When the power supply voltage is larger than upper limit voltage or the motor current is larger than 20% of the set value, the protection circuit will cut off the PWM output, the ALM LED will alarm.

Note: If the protection circuit works, the driver cannot work fine unless eliminate the error and power on again, after the PWR LED is green, the driver can recover.

4. Dimension and Installation

4-1. Dimension

Unit: mm

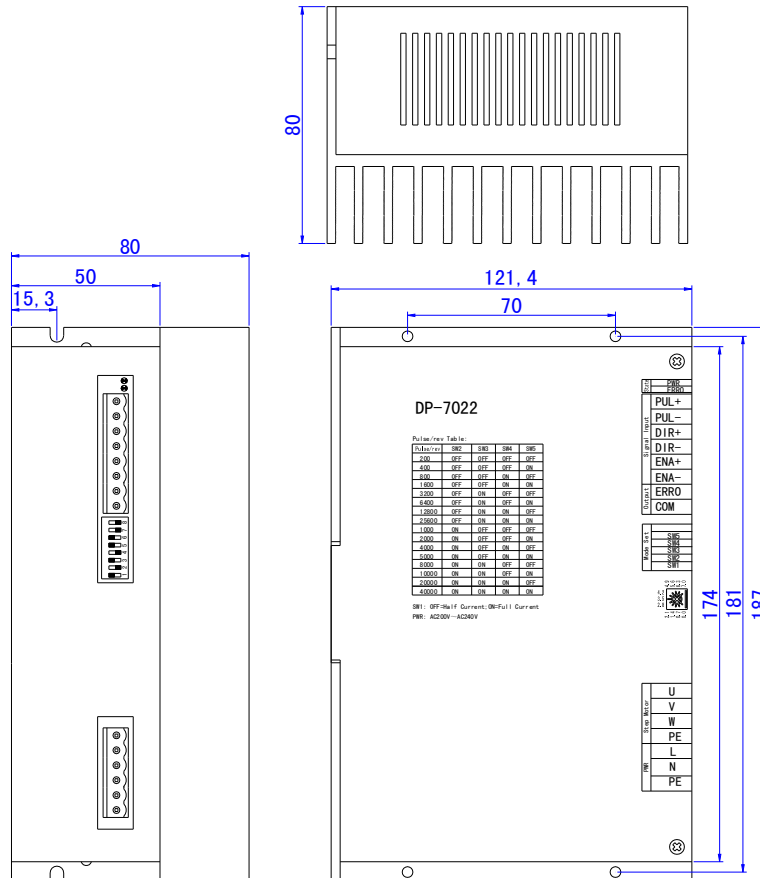

4-2. Installation

The driver must install in the electric cabinet of good ventilation and protection. Periodic inspect if the cooling fan works fine. Make sure the heat dissipation of the driver is well, keep at least 10cm installation space. Do not let the dust or scrap fall into the driver.

4-3. Typical wiring

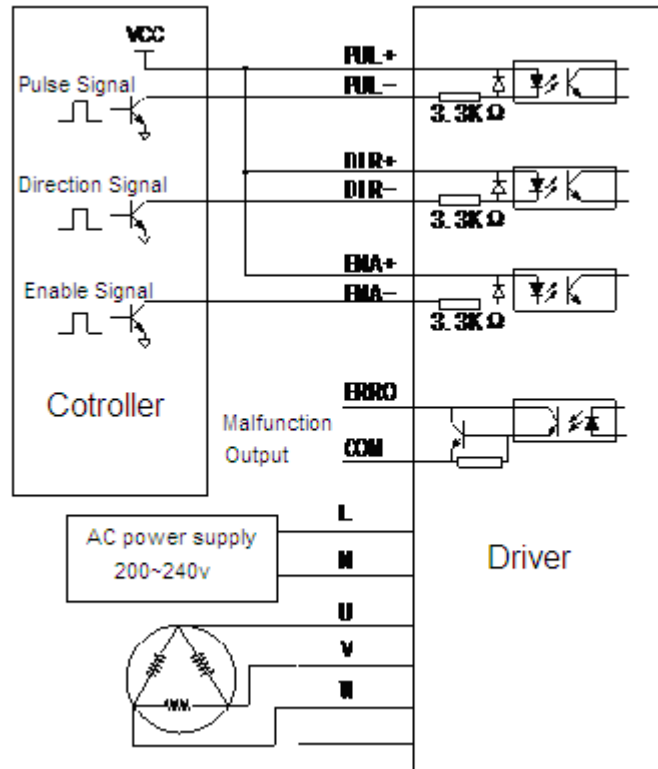

Note: Please separate the power cable (motor and power supply cables) and weak electricity (signal cables) cable to avoid interference.

5. Problem and solution

Problem	Reason	Solution
PWR LED is OFF	Something wrong with the power supply system	Check the power supply system
	Power supply voltage is low	Increase the power supply voltage
Motor does not turn	Set the current too small	Reset the current
	The subdivision is too small	Reset the subdivision
	Protection circuit works	Power on again
	Release signal is low	Disconnect this signal
	No power	Power on again
	Motor wiring is error	Check the motor wiring
	No pulse input	Adjust pulse width and voltage
Motor direction is wrong	Motor phase is opposite	Exchange any phase cable
	Circuit is cut off	Check the circuit
ALM LED is ON	Motor wiring is wrong	Connect the wire again
	Over-voltage or under-voltage	Adjust the voltage
	Motor or driver is broken	Check motor and driver
Motor torque is small	Acceleration is too fast	Decrease the acceleration
	The motor does not match with the driver	Change the driver

6. Select the motor

DP-7022 is suitable for 3/6-wire 3-phase hybrid stepper motor. Generally speaking, select the motor according to the torque and rated current. The torque depends on the motor dimension. Big dimension motor has big torque. The current depends on the resistor. Small resistor has large current and the motor will have good performance at high speed.

For certain wiring motor, the bigger the working current, the larger the output torque, the motor heating is serious. The higher the drive power voltage, the bigger the motor high-speed torque. The motor high-speed torque is smaller than low-speed torque.

